



Released Date 1/11/21

2021 SO CAL SPORTSMAN Sprint Car Rules

DISCLAIMER:

The rules and/or **regulations** set forth herein are designed to provide for the orderly conduct of racing events and to establish minimum acceptable requirements for such events. These rules shall govern the condition of all events, and, by participating in these events, all participants are deemed to have complied with these rules. **No expressed or implied warranty of safety shall result from the publication of or compliance with these rules and/or regulations.** They are intended as a guide for the conduct of the sport and in no way a guarantee against injury or death to a participant, spectator, or official.

EACH race director shall be empowered to permit reasonable and appropriate deviation from any of the specifications herein or impose any further restrictions that in his opinion do not alter the minimum acceptable requirements. **No expressed or implied warranty of safety shall result from such alterations of specifications.** Any interpretation or deviation of these rules is left to the discretion of the officials. Their decision is final.

On occasion when situations arise that are not covered by written rules, special rulings may be put into effect by the Series of Track Officials. Once such rulings are acted upon, they *may* be added to the existing rules and/or procedures.

The SO CAL SPORTSMAN SPRINT CAR SERIES will compete at the Perris Auto Speedway and the Ventura Raceway. There will be an overall series Championship along with separate Track Championships. Information regarding Race Format, Championship Points, Entry Fee's and Purse's are discussed at the end of these rules. THE DIRECTORS OF THE SO CAL SPORTSMAN SPRINT CAR SERIES is Don Kazarian/Perris Auto Speedway and Jim Naylor/Ventura Raceway

Contact Info:

Don Kazarian – Perris Auto Speedway
Email: kazariandon@gmail.com

Jim Naylor – Ventura Raceway
Email: jnaylor222@aol.com

Engine sales and/or technical support contact Don Blackshear at Pace Performance
888-748-4655 E-mail: donblackshear@paceperformance.com

Website/Link: <https://paceperformance.com/i-20758461-gmp-88869602-s-pace-gm-factory-sealed-602-sprint-car-crate-engine.html>

A LOCAL DEALER AND ENGINE SERVICE FACILITY WILL BE NAMED IN THE NEAR FUTURE.

AGE REQUIREMENTS:

Anyone 14 – 17 years old (subject to a Birth Certificate or Passport) are eligible to compete in this Series at both tracks. Anyone younger than 18 years old must have their parent or legal guardian execute a “Minors Release of Liability” form prior to competing in the series.

GENERAL CODE OF CONDUCT:

THESE GENERAL CODE OF CONDUCT MAY BE SUPERSEDED BY EACH TRACK’S OWN CODE OF CONDUCT POLICIES.

1. **General** - All drivers crew chief, car owner, crew member and/or team representative agree to act in a professional manner as determined by Track Officials. The professional manner includes, but is not limited to verbal representation, written representation, any representation that may represent the SO CAL Sportsman Sprint Car Series. Verbal abuse may result in an immediate disqualification from the event. Repeated violation(s) may also warrant fine and/or suspension.
2. While we recognize your right to express opinions on social media, drivers and crew members should be advised that threats against officials, other drivers or crew members will not be tolerated. Any action by a driver or crew which appears to be the execution of a threat will result in penalties via suspensions and/or fines against the driver and/or car owner. The driver or car owner will be held responsible for the actions or members of his or her crew.
3. Any driver/owner that disparages SO CAL SPORTSMAN SPRINT CAR SERIES in any publication (including messages boards, social media, etc.) may be suspended for a minimum of one event and/or fined.
4. All drivers must arrive at Series races in a timely manner so that they may participate in the entirety of the racing event.
5. No driver will be permitted to compete and/or participate while under the influence of any alcoholic beverages and/or illegal substances. If a driver is found to be participating in such a manner, an immediate suspension will be invoked.
6. Any driver, during an event; a competitor, crew chief, car owner, crew member and/or team representative may be requested to report to the Pit Board for consultation with Track Officials. The request may be communicated over the one-way radio and/or verbally. Failure to comply with the request will be subject to fine and/or suspension and/or any other action deemed appropriate by Track Officials.

The SO CAL Sportsman Sprint Car Series is a professional organization and will conduct itself so in its dealings with everyone, including fans, drivers, team members, Series sponsors, team Sponsors, tracks and the media. The Series therefore expects the same from its drivers, team members and team sponsors. The Series organizers and officials therefore reserve the right to take disciplinary action against anyone who brings the Series into disrepute by their actions, either on or off the track.

In the event of any felony conviction of a driver, team member or team sponsor, the disciplinary action shall be a minimum one-year ban from the Series, beginning with the date of the conviction, or, the date of the completion of any incarceration subsequent to said conviction, whichever date shall last occur.

Disciplinary action may also include, but is not limited to, the right of the Series organizers and officials to suspend either temporarily, or permanently, any driver, team member or team sponsor whose actions, in the sole opinion and discretion of the Series organizers and officials, may have resulted in, or may result in, harm or detriment to the SO CAL Sportsman Sprint Car Series events.

The Series organizers and officials also reserve the right to request the removal of any derogatory or distasteful statements on any racecar or hauler. Failure to comply with this request for removal may result in disqualification from some or all of the SO CAL Sportsman Sprint Car Series events.

Participants grant and assign to SO CAL Sportsman Sprint Car Series, its affiliates and SO CAL Sportsman Sprint Car Series Sponsors the non-exclusive rights and authority to use my image and likeness, including my name, nickname, initials, picture, photograph, animation, persona, autograph/signature (including facsimiles thereof), voice, biographical information, and/or any and all other identifying characteristics, including the image of my vehicle, whether portrayed in still or action pictures, drawings, or other artistic renderings, in connection with my participation in SO CAL Sportsman Sprint Car Series Events and for any and all uses or purposes that publicize and promote SO CAL Sportsman Sprint Car Series or any of its affiliates in any way in any and all media or formats.

ENVIRONMENTAL WARNING:

1. **Any driver or crewmember** found to be altering, by means of contaminating the racing surface or pit area or racing entrances and/or staging or technical inspection areas or **ANY** part of the event grounds or properties and nearby driveways will be **disqualified**. The local authorities and/or agencies may be notified and the violator(s) and their information may be turned over to these authorities at that time.
2. **No race cars or vehicles** including, but not limited to **race trailers, or support vehicles or trailers** will be allowed to carry or conceal, in marked, unmarked or using any form of misrepresentation of jugs or bottles or carrying devices of any type (with

concerns to chemicals), for the purpose of altering, conditioning or changing a tire's baseline settings (from its original factory set baseline settings) will be allowed in or around the/any SO CAL SPORTSMAN SPRINT CAR SERIES Event/s. All local authorities and applicable agencies may be called and the violators and their information will be turned over to these authorities at that time.

TECHNICAL RULES & REGULATIONS

It is ultimately the obligation of each participant to ensure that their conduct and equipment complies with all of the applicable rules, as they may be amended from time to time; any amendments supersede any previous rules regarding any technical and/or aspect. An amendment is effective upon the date of the publication of the amendment regardless of when a competitor receives the actual notice.

Any new components, including engine components, suspension components, body designs, frame designs and/or components of any type utilized in competition must be approved by Track Officials prior to being introduced into competition.

ENGINES:

1. The General Motors (GM) Engine part number 19370602 19258602 is the only engine permitted in all SO CAL SPORTSMAN SPRINT CAR SERIES Sprint Carevents.
2. All engines utilized in this division MUST be purchased from Pace Performance (50 Kargo Ave., Boardman, OH 44512 - Contact Don Blackshear at 330-726-3802). Note: SO CAL SPORTSMAN SPRINT CAR SERIES Authorized Engine Rebuilders MUST also purchase engines from Pace Performance.

The mandatory base engine package from Pace Performance included the following:

- GM Engine part number 19258602
- Crate Innovations CII-2001 crank, hub & yoke assembly
- Crate Innovations BLK216 carb spacer & linkage
- 6 official SO CAL SPORTSMAN SPRINT CAR SERIES wire cable seals plus one additional SO CAL SPORTSMAN SPRINT CAR SERIES QR coded wire cable seal (all installed & recorded for engine tracking)
- Rear of camshaft will be drilled and tapped to accept spud to operate cockpit fuel and power steering pumps
- Installation of low profile oil pan and oil pump pick-up
- A complete engine sale and seal tag reporting form

Additional MANDATORY components that may be installed by Pace Performance, a SO CAL SPORTSMAN SPRINT CAR SERIES Authorized Rebuilder or Racer:

- One unaltered approved MSD RPM (rev) limiting box, part number 8727CT. The black wire must be grounded to the motor. Rev limiter box MUST be set as 6,200 RPM. The box must remain operable and working condition, prior to, during and after all racing events. The rev box must be in clear view without removing the hood.

PENALTIES: *If rev limiter box is found to be not set at specified RPM of 6,200, driver and car will be disqualified for the night's events and both driver and car owner will be suspended for the next completed SO CAL SPORTSMAN SPRINT CAR SERIES Sprint Car event*

The wiring must remain as specified by the ignition amplifier box manufacturer.

PENALTIES: *If wiring is found not to be installed properly per amplifier box manufacturer's specific instructions, driver and car will be disqualified for the night's events and both driver and car owner will be suspended for the next SO CAL SPORTSMAN SPRINT CAR SERIES event.*

- One unaltered Holley 750 CFM Classic HP Carburetor, mechanical secondary, calibrated for methanol part #0-80535-1
 - One Chevrolet Performance installed HEI distributor & ignition is required. The distributor advance curve may be "locked". Competitor may be asked for electronic ignition at any time to be sent for testing and inspection. Failure to relinquish electronic ignition will result in disqualification (loss of points and monies) and "refusal of tech" penalties.
 - All remaining parts must be stock as manufactured
 - Schoenfeld Headers steel part # 1022LCM2 is required. Collectors or modifications to headers will not be permitted.
 - If required, Schoenfeld part #63030 mufflers are mandated. Mufflers must remain unaltered from the manufacturer and remain attached to the headers at all times. All muffler and header components must remain intact and operating. All mufflers must be welded and securely mounted. Mufflers that are mounted with pop rivets and/or sheet metal screws will not be permitted.
3. The General Motors (GM) Engine part number 19258602 Pace Performance sealed pro sprint engines will also be allowed to compete under these guidelines; engine must retain all 6 official Pace registered wire cable seals along with the Pace QR coded tracker seal, and the engine is also required to have a SO CAL SPORTSMAN SPRINT CAR SERIES QR coded wire cable seal installed prior to competing in any event.

4. All engines are to remain sealed from the factory. These engines are sealed at the intake manifold, cylinder heads, front cover, and oil pan with special GM twist off bolts or cap seals. The original factory seals (bolt-type or cap seals) must remain unaltered. Tampering, removal, or modifications of any type and/or broken factory seals, bolt type or cap seals, will not be permitted and will result in an immediate disqualification from the event (loss of points and money). The engine may be impounded immediately for further inspection.
5. The exception to this will only be in the event a rebuild/repair is required. This rebuild/repair must be authorized by The SO CAL Sportsman Sprint Car Series office, at which time the engine may be repaired/ or possibly rebuilt providing all guidelines and specifications set forth in the GM Technical Manual #88958668 are met; otherwise the GM Engine must remain unaltered in any way.
6. Only SO CAL SPORTSMAN SPRINT CAR SERIES seals will be accepted in the event of an engine repair/rebuild, and must be installed by a SO CAL SPORTSMAN SPRINT CAR SERIES Authorized repair facility.
7. Engines must be sealed in all of the above locations with either the "original" GM twist off bolt heads or cap seals, SO CAL SPORTSMAN SPRINT CAR SERIES seal tags, or a combination of the "original" GM twist off bolts or cap seals, and/or SO CAL SPORTSMAN SPRINT CAR SERIES seal tags.
8. The sealed engines must remain intact and not be tampered with; **any seals** that have been tampered with, removed, or modified, and/or broken will make the engine illegal and will result in an immediate disqualification from the event (loss of points and money). The engine may be impounded immediately for further inspection. Modifying any internal engine parts or changing the parts from stock as delivered sealed from the factory will result in disqualification for the night's event (loss of points and money), loss of all Series points to date in the division the infraction occurred in, suspension from all Series competition for 365 days, fined \$1,000, and an indefinite probation; penalties apply to both driver and car owner.
9. The permitted crate engines must not be altered, modified, or changed from the GM specifications set forth in the GM Technical Manual #88958668; no changes are allowed to the engine- intake manifold, heads, valve covers, front cover, oil pan, harmonic balancer, or any other part or parts on or in the engine.
10. Only GM parts will be permitted for rebuild/repair work excluding engine bearings. Replacement engine bearings can be OEM. Replacement bearings must be the same dimensions as the factory GM bearing and/or .002 in all dimensions. NO bearing coatings allowed!
11. Only GM Crate Engine specific valve springs may be used for replacement and/or repair, Part Number # 10212811 for singles or part number 19154761 for kit of 16 springs. Valve springs may be shimmed to GM manual specs only.
12. SO CAL SPORTSMAN SPRINT CAR SERIES GM Crate Engine rebuild/repairs must be authorized by SO CAL Sportsman Sprint Car Series. SO CAL SPORTSMAN SPRINT CAR SERIES GM Crate Engine rebuild/repair procedure works as follows:
 - A. SO CAL SPORTSMAN SPRINT CAR SERIES authorized rebuild/repair center must complete the SO CAL Sportsman Sprint Car Series Engine Seal Request, Engine Parts Release, and Engine Owner & Authorized Rebuild/Repair Facility Agreement forms must be completed in their entirety and EMAILED to Don Kazarian (kazariadon@gmail.com) or Jim Naylor (jnaylor222@aol.com) to receive permission for an engine to be rebuilt or repaired.
 - B. Only SO CAL Sportsman Sprint Car Series authorized engine rebuild/repair facilities may be utilized.
 - C. Upon completion of the rebuild/repair(s) the engine must be 'resealed' using SO CAL SPORTSMAN SPRINT CAR SERIES seals before being released for competition.
 - D. All engine information regarding rebuild/repairs and/or engine introduction must be retained by SO CAL SPORTSMAN SPRINT CAR SERIES Authorized Engine Repair Facility and emailed to kazariadon@gmail.com to be recorded into the rebuilt/repared engine spreadsheet, which includes the engine owner, driver at time of rebuild/repair, engine serial number, repair, type of repair and/or what type of service was performed to any engine, along with SO CAL SPORTSMAN SPRINT CAR SERIES seal numbers and specific location of the seals.
13. Engine's GM serial number and when applicable SO CAL SPORTSMAN SPRINT CAR SERIES build certification number must be clearly visible to Series' or track technical inspectors.
14. SO CAL Sportsman Sprint Car Series Officials reserve the right to inspect exchange and/or confiscate any GM Crate engine, or other specified engine component. Refusal to surrender an engine or other engine part for inspection, exchange or confiscation, will result in disqualification for the night's event (loss of points and money), loss of all Series points to date in the division the infraction occurred in, suspension from the Series competition for 365 days, fined \$1,000, and an indefinite probation; penalties apply to both driver and car owner.
15. ANY VIOLATION OF THE ENGINE RULES AND/OR FACTORY SPECS INSIDE THE SEALING SYSTEM OF THE ENGINE WILL result in disqualification for the night's event (loss of points and money), loss of all Series points to date in the division the infraction occurred in, suspension from all Series competition for 365 days, fined \$1,000, and an indefinite probation; penalties apply to both driver and car owner.

After the suspension period, the driver and/or car owner can only compete in Series events with an engine equipped with original factory GM sealing bolts or cap seals, or SO CAL SPORTSMAN SPRINT CAR SERIES seal tags. For subsequent violations in regard to any illegal modification to any GM Performance Parts Crate Engine, an indefinite suspension may be issued.

16. Any violation of the engine rules and/or factory specs outside the original GM twist off bolt heads or cap seals and/or permitted Series seal tags on the engine will result in the driver and car being disqualified from that event (loss of points and money). Multiple infractions outside the sealing system will result in the penalties stated in the "Multiple Infractions" section of the rules.
17. The engine must be centered in the front of the chassis and placed in an upright position.

ENGINE PROTESTS/SELECTION:

1. Any race track and/or SO CAL SPORTSMAN SPRINT CAR SERIES Director(s) are authorized to call for an engine inspection or tear down *at any time*. Tear down and inspection will be performed by SO CAL SPORTSMAN SPRINT CAR SERIES Tech/Competition Director. If this happens, Track/Series will remove engine at race track and impound until inspection day can be arranged for all parties involved. (See paragraph number five for procedures if selected car is to race in successive events.)
2. The protest fee for a complete teardown of an engine that finishes the A main in the top five is \$2,000, and must be made by a driver/owner that finishes in the top five. \$300 of protest fee will go to Series or Track and the remaining \$1,700 will go to the winner of the protest.
3. The protest fee for a partial tear down of an engine that finishes the A main in the top five is \$1,500, and must be made by a driver/owner that finishes in the top five. \$300 of protest fee will go to Series or Track and the remaining \$1,200 will go to the winner of the protest. A partial tear down will include the following: cam profiled along with the timing components, lifters, and cylinder heads verified.
4. Protest and fee in cash must be made to the specific track (i.e. Perris Auto Speedway) given to the Tech Inspector, Race Director, or Track Tech Inspector and paid within 15 minutes of the checkered flag of the feature. Protest cannot be withdrawn once it has been declared. **Protested competitor cannot counter- protest in the same event.**
5. At any time an engine is protested and driver/car owner accepts protests and agrees to tear down, the engine being protested must be removed immediately and impounded by Series/Track. Protested engine will be sealed by SO CAL SPORTSMAN SPRINT CAR SERIES Official or person(s) appointed by SO CAL SPORTSMAN SPRINT CAR SERIES to insure that it has not been tampered with, and to verify engine's identity. Any refusal to permit engine confiscation will result in disqualification for the night's event (loss of points and money), loss of all Series points to date in the division the infraction occurred in, suspension from all Series competition for 365 days, fined \$1,000, and an indefinite probation; penalties apply to both driver and car owner.
6. *If the protested car wishes to race in successive PAS-sanctioned events within 72 hours (three days) the following will apply ONLY at the discretion of a SO CAL SPORTSMAN SPRINT CAR SERIES DIRECTOR (Don or Jim) reserve the right and also grants the right to the speedway tech officials to seal or otherwise identify the protested engine to allow the car to compete in successive events within 72 hours (three days). Further postponement of tear-down will be at the discretion of SO CAL SPORTSMAN SPRINT CAR SERIES Directors. The driver and/or owner has the option whether to surrender the engine on the night it's protested or have it identified and retained for the successive races. However, if the driver chooses to compete with the engine after its selection for tear down, and that engine is found to be out of compliance with SO CAL SPORTSMAN SPRINT CAR SERIES Technical/Engine rules, the driver will be disqualified from all races entered after the engine was protested, in addition to the race when engine was protested. SO CAL SPORTSMAN SPRINT CAR SERIES may assess penalties for each race in which the selected engine was used after its selection, if it is found to be illegal. If the engine is found to comply with all applicable rules, then driver/owner will be awarded all money and points earned for each event.*
7. At this time, the feature finish will be frozen until inspection is complete. In the event of a disqualification, finishing position, points and monies would be adjusted accordingly.
8. Failure and/or refusal to tear down an engine and/or for your race car to be inspected by the Series Officials at any time will result in disqualification for the night's event (loss of points and money), loss of all Series points to date in the division the infraction occurred in, suspension from all Series competition for 365 days, fined \$1,000, and an indefinite probation; penalties apply to both driver and car owner.
9. Inspection location will most likely be at approved local Dealer and Service Facility. Although other inspection locations could be selected. There will be no dispute over SO CAL SPORTSMAN SPRINT CAR SERIES DIRECTOR'S choice of location.
10. Driver and/or car owner and one other representative of the team will be allowed in the tech area during the engine teardown. Only one representative from the team protesting the engine will be allowed in the tech area during the engine teardown. Additional attendees must be approved by SO CAL SPORTSMAN SPRINT CAR SERIES pursuant to a written request. Protestor and protested driver and/or car owner along with the confiscated sealed engine and/or parts must be present at predetermined location. All parties must remain present during the entire tech procedure.
11. Note: All removed original GM bolts or cap seals and/or SO CAL SPORTSMAN SPRINT CAR SERIES Seals must be returned immediately to the current approved Engine Service Facility.
12. Engine infractions "within the bolts" will result in disqualification for the night's event (loss of points and money), loss of all Series points to date in the division the infraction occurred in, suspension from all Series competition for 365 days, fined \$1,000, and an indefinite probation; penalties apply to both driver and car owner.

13. In the event that the series confiscates an engine, for inspection, and said engine is found to be legal, and comply with the all the rules, the "Series" will provide a full GM gasket set, and the seals to reassemble engine at no charge to the authorized rebuilder and engine owner. If engine is protested by another racer for inspection, the engine owner is responsible for all expenses required for reassembly.

CARBURETOR/THROTTLE

1. Carburetor must be run as produced and must pass gauge test. Jets and power valves may be changed.
2. Carburetor must be mounted parallel to intake.
3. Air induction inserts or other devices to direct air to intake are not permitted.
4. Fuel regulator required.
5. A minimum of two return springs must be connected to the throttle.
6. Pipe plugs must remain in manifold heat crossover port on GM 602 crate engines.
7. No carburetor spacer permitted other than throttle linkage plate, part #BLK-216, between the carburetor and intake manifold.
8. Holley 26-342 float bowl vent tube check valves are mandated.

AIR FILTER:

1. One round type air filter element maintaining a minimum of 4 inches and a maximum of 14 inches.
2. K&N Style Air Filters are permitted.
3. Air filter top and bottoms must be steel or aluminum; plastic air filter top or bottoms are not permitted.
4. All air shall be filtered through the filter element.
5. Carburetor inserts to direct air into the carburetor are not permitted.
6. Air boxes, hoses, or any device that directs air into the air cleaner are not permitted.
7. Hood scoop permitted, but cannot be sealed to the air cleaner assembly.

COOLING SYSTEM:

1. Crankshaft belt driven water pumps only.
2. Fans, if used, must be water pump driven. Fans must be steel, aluminum, or plastic if utilized. No electric fans permitted.

BATTERY AND CHARGING SYSTEM:

1. 12-Volt sealed battery required. The battery voltage must not measure more than 14.3 volts. Step up transformer and/or any other device designed to increase voltage will not be permitted. No 16 volt or lithium batteries permitted.
2. Battery must be securely mounted with positive fasteners and brackets in the engine compartment. The battery terminals must be insulated and enclosed with a non-conductive material that will prevent contact with any part of the race car should the battery become dislodged from the battery mount.
3. A clearly marked main electrical shut off switch, within the driver's and safety crews reach, is mandatory and must be mounted in the driver's compartment.

FUEL PUMP:

1. Fuel pump MUST be driven from the rear of the camshaft in conventional sprint car location.

FUEL/FUEL CELL:

1. Any brand of Methanol will be permitted for SO CAL Sportsman Sprint Car Series events. In the event an "OFFICIAL FUEL" is announced, there will be a grace period so the race teams can use their existing fuel inventory prior to a mandate to use the Official Fuel.

Additives and/or blending of any type or other performance enhancing chemical additives will not be permitted. Fuel may be tested from time-to-time and/or submitted for verification by designated SO CAL Sportsman Sprint Car Series and/or Track Officials to Sunoco Race Fuels. **It is the racer's responsibility to know what he or she is putting in the fuel cell.**

2. Series reserves the right to check fuel anytime. Three samples will be taken by SO CAL SPORTSMAN SPRINT CAR SERIES or Track Official. Each sample will be identified as sample #1, sample #2, and sample #3. Sample #1 will be retained by Series and sent to the lab; sample #2 will be given to selected fuel's driver/owner; and sample #3 will be retained by Series to be utilized as a tie-breaker in the event any issues may occur with samples #1 & #2. In the event driver/owner chooses to send sample #2 to be analyzed, SO CAL SPORTSMAN SPRINT CAR SERIES must approve the selected lab. Fuel samples not conforming to SO CAL SPORTSMAN SPRINT CAR SERIES Fuel rule will be deemed illegal.
3. Series Officials may amend the fuel rule for any event, and will inform competitors.
4. **PENALTIES FOR FUEL VIOLATIONS:** Disqualification from event (loss of points and money) in addition to the following penalties:
 - First Offense: \$500 fine & 30-day suspension from any future event plus all related lab testing costs.
 - Second Offense: \$1,000 fine & 90-day suspension from any future event plus all related lab testing costs.
 - Third Offense: \$2,000 fine & 365-day suspension from any future event plus all related lab testing costs.

ALL DECISIONS ARE FINAL!

5. A conventional tail tank fuel cell is required. The fuel cell must be of once piece construction of cross link polyethylene plastic. Alterations and modifications will not be permitted. Fuel cell must meet SFI Specification 28.2.
6. The same fuel cell/tank must be used in the same car for the entire race program. The fuel cell/tank may be changed at the discretion of the SO CAL SPORTSMAN SPRINT CAR SERIES if the cell/tank has been contaminated and/or physically damaged for any unforeseen reason.
7. For the purpose of inspection, the driver and/or crew must be prepared to drain fuel upon request for inspection and/or measurement.
8. A clearly marked fuel shut-off valve, within the driver's and safety crews reach, is mandatory and must be mounted in the driver's compartment.
9. On board fire suppression system is highly recommended.

BRAKES:

1. Steel or aluminum rotors only; carbon fiber or carbon composite brake discs or components are not permitted.

DRIVE TRAIN/REAR END:

1. Standard conventional Sprint car style rear ends only, no midget or hybrid rear ends. Ring gear dimension minimum 10".
2. Magnesium rear end center section, bells and rear cover are permitted.

DRIVESHAFTS:

1. Steel driveshaft's only.
2. A drive line containment system; a steel torque ball housing made of a minimum of .120 wall thickness magnetic steel attached to the firewall with steel bolts is mandatory. A torque ball u-joint containment blanket is highly recommended in conjunction with the drive line containment system to shield revolving parts within the cockpit.

CHASSIS/FRAME:

1. All cars must be rear drive only
2. Roadster type chassis will not be permitted
3. Only torque tube style drivelines, utilizing one U-joint will be permitted. The torque tube must be bolted directly to the face of the rear axle center section without any interruptions; the torque tube must be one solid piece.
4. The driver must be seated directly behind the engine; centerline of top of seat at the driver's helmet cannot be any more than 1" off centerline of roll cage.
5. All cars must have a roll cage, which is integral with the frame and does not encroach upon an imaginary cylinder, 20 inches in diameter, extending through the top cockpit opening directly above the seat. The roll cage should extend 4" above the driver's helmet when seated in the driving position.
6. The following frame measurements are minimum dimensions. Only those areas indicated are mandatory and subject to technical inspections. In lieu of the "butt" bar, a car's rear end can be tethered to the rear chassis. ASTM4130 normalized steel is suggested. See drawing 16.8.a.r.
7. Top rails 1 1/2" x .095", bottom rails 1 3/8" x .095" or 1 1/2" x .083". Roll cage uprights 1 3/8" x .083". Roll cage cross member 1 1/2" x .095"

8. Upper rails 1 3/8" x .083". Rear end safety "butt" bar 1" x .083" or 1 1/4" X .065 brace 1 1/4" x .065"
9. Sprint Car roll cage halos are mandatory. Halo minimum 1 1/2" x .095".
10. All chassis will be required to have additional bars installed to support and decrease the span between the front and rear uprights in the drivers area. The new support bars must be in addition to the front and rear uprights. Any attempts to manipulate the front and rear uprights to conform to these measurements will not be allowed at the discretion of SO CAL SPORTSMAN SPRINT CAR SERIES Officials. These additional bars will be minimum 1.375 X .083 ASTM4130 normalized steel or equivalent material as per SO CAL SPORTSMAN SPRINT CAR SERIES current rule.

Left and right side support bars may be one of the three designs below. Left and right side support bars do not have to be of the same design.

Left and right side support bars may be one of the three options:

- A. Support bar may be designed similar to what was known as a "safety bar". It must be attached to the top rail at a point 15" to 20" from the rear of the front upright. It must attach to the hip rail and have a gusset attached to the rear upright near a point opposite of the rear brace/shock mount bar. The curve must be between 4" and 7" measured from outside of the rear upright tube to the outside of the support bar. See Diagram #16.12.1
 - B. Existing chassis with a left side support bar installed (formerly called safety bar) that do not meet the option one specification above, may add a gusset that attaches to the top rail 15" to 20" from the rear of the front upright and angle to the support bar. The existing support bar tubing must meet the minimum as described above (1.375 X .083 ASTM4130 normalized steel or equivalent material). See Diagram #16.12.2
 - C. A support bar may be added to the top rail at a point 15" to 20" from the rear of the front upright and to the rear upright near a point of the rear brace / shock mount bar but no higher than 7" above the hip rail. This bar may have a slight curve near the rear upright to accommodate elbow room and ease of fitment. See diagram #16.12.3
11. Slip-tubing is not allowed in the chassis construction. Any existing slip-tubing must be replaced or welded. Clamped or bolted slip tube joints will no longer be allowed.
 12. The chassis must have a minimum of four (4) mounting points for securely mounting any manufacturer's seat per the seat and chassis manufacturer's specifications.
 13. Nerf bars and rear bumpers must be made from magnetic steel and/or stainless steel. The bumpers must be a minimum of one (1) inch in diameter and have a minimum material thickness of .065 inches.
 14. Full size nerve bars are mandated. Nerf bars must have a forward attachment point, forward of the front motor plate, and must be positively fastened with bolts & nuts. Left and right nerve bars must attach to the chassis at three points. Nerf bars may not extend past the outside edge of the tires.
 15. The front bumper must not extend more than eight (8) inches from the frame and/or the measurement from the center of the front axle to the front of the front bumper must not exceed 23 1/2 inches.
 16. For any car to be pushed off at any time the rear bumper must be in place behind the tail tank.
 17. The top of the roll cage shall have a maximum outside width of 29.5 inches. Bracing that would prevent the driver's ability to exit through the opening and/or inhibit safety/rescue workers ability to extract the driver will not be permitted.
 18. The cockpit horizontal middle frame bar will have a maximum outside width of 28.5 inches.
 19. The bottom frame rail will have a maximum outside width of 26.5 inches.
 20. All tubing utilized in the construction and/or fabrication of the main frame must be round in shape. Any other shapes, such as elliptical (oval) tubing will not be permitted.
 21. Only steel or aluminum floor plans will be permitted.
 22. The minimum wheelbase will be 83 inches. The maximum wheelbase that will be permitted will be 90 inches. Centerline rear axle to front king pin center line.
 23. Front anti-roll torsion bar assemblies (sway-bars) will not be permitted.

STEERING & SUSPENSION:

1. Removable steering wheels incorporating a quick release mechanism conforming to SFI Specification 42.1 are mandatory. Pip pin type mechanisms are not allowed.
2. No independent suspension
3. No rack and pinion steering allowed or any type of steering dampeners permitted.
4. Welded aluminum or titanium suspension parts prohibited.
5. No electronic weight, shock, sway bar or any other suspension item adjuster permitted.

6. Radius rods must be attached to the chassis and axle attachment points with said rod ends and no other devices between rod ends and attachment points will be allowed. Radius rods may not be attached within the confines of the cockpit. Devices that are designed to change the length of a radius rod in any way while the car is moving will not be allowed. Items such as but not limited to springs, air chambers and/or shock absorbers will not be allowed in any form on radius rods.
7. Radius rod protectors will be permitted. Vertical openings 10" in height x 24" long and extend no more than 4" from outside edge of lower frame rail.
8. Maximum of four torsion bars; no coil over type suspensions permitted.
9. Drag links must be made of 4130 steel a minimum of one (1) inch in diameter and a minimum material thickness of .058 inches. Tie rod and left front radius rod must be 4130 steel with magnetic steel rod ends. Swaging of the tubing for tie rod and drag link will not be permitted. The drag links must be tethered to the frame with a minimum of one (1) inch nylon webbing.
10. Hollow and/or drilled bolts, fasteners, and/or hemi joints (rod ends) will not be permitted.
11. Front axles must be made of magnetic steel. Maximum width is 54" measured on centerline of axle with a minimal tube diameter of 2 1/4". Axles with a tube diameter of 2 1/4" must have a minimal wall thickness of .120". Axles with a tube diameter of 2 3/8" or 2 1/2" must have a minimal wall thickness of .095".
12. Front hubs are to be constructed of aluminum or magnesium only.
13. Front axle tether systems are highly recommended. If utilized the tether mounting must meet the SFI 55.1 specifications which includes two (2) Veteran® HS V-12, or Dilemma 12 tethers attached to the chassis. Tether systems must include a "king pin to king pin" tether that will attach to the axle clamp/band. Tether cables should be installed using the manufactures provided fasteners. Tethers of any type must be installed and used in accordance with the manufacturer's instructions.
14. Torsion arm stops are mandated on both sides of the front torsion bars. The retainer may be of the rod-type with a securing cap or insert with an expanding mandrel and/or any other Series approved torsion arm stop design. Torsion arm stops must be installed and used in accordance with the manufacturer's instructions. The following torsion bar stops(s) are recommended:
 - Moose Block 1200 Retainer Kit
 - All Star Performance All Star 10730 Retainer
 - Marring Safety Retainer
 - Butler built Mandrel
 - DMI – T-REX (Torsion Restraint Express System)
 - Schroeder Part number "BARS" (for Schroeder bars with relief in ends), Schroeder Part Number: "RWLAR" (Wedge Lock)

The recommended torsion arm stops part #'s may be revised from time-to-time.

EXOTIC MATERIALS:

All exotic materials are illegal including titanium, tungsten and/or carbon fiber. Exception: magnesium rear end center section, bells, and rear cover along with wheel centers, and front axle hubs will be permitted. Carbon fiber seats will also be permitted. No other magnesium parts will be permitted.

WHEELS:

1. Only aluminum wheels will be permitted. Plastic and/or carbon fiber wheels are not permitted.
2. The wheel diameter must be 15".
3. The wheel width for drive wheels is limited to a maximum of 18" on the right rear and a maximum of 15" on the left rear.
4. A tire bead locking device must be utilized on the outer bead seat of the right rear tire and wheel assembly.
5. All wheels centers must be aluminum or magnesium only and are subject to SO CAL SPORTSMAN SPRINT CAR SERIES approval.
6. All bolts are mandatory in bead lock and wheel centers.
7. Tire bleeders of any kind will not be permitted.

WHEEL COVERS:

Only steel wheel cover fasteners permitted. It is highly recommended that wheel covers have a minimum of 5 mounting points. However, 5 and 3 mounting point wheel covers will be allowed for competition under the following conditions: Wheel covers having a minimum of 5 attachment points may continue to use steel dues fasteners. Dues fasteners must be made of steel only. Wheel covers having only 3 attachment points must be bolted-on at all 3 points utilizing a minimum 1/4" or 5/16" magnetic steel hex head bolt and an approved fastening (nut assembly) system.

Approved fastening (nut assembly) systems:

1. Precise Racing Products Part # WCBK

2. Keyser Manufacturing Part #100 7-101.
3. Wears Manufacturing Part # WM377A-312 Aluminum 5/16" / WM377S-312 Steel 5/16"
4. Triple X Chassis Part # SC-WH-7810(for a 1" spring) / SC-WH-7820 (for a 1 3/8" spring)
5. Smith Precision Products Part # MC-516-18

Optional fastening systems that are equal or superior to the above-approved system will be readily approved at the sole discretion of Technical Officials.

TIRES:

1. Front Tires:
 - Any 8" wide front Hoosier Tire is legal. Hoosier 85.0/8.0-15 D12, D15, or D20 are recommended.
2. Rear Tires:
 - Left Rear:
 - SO CAL SPORTSMAN SPRINT CAR SERIES 92.0/14.0-15
 - SO CAL SPORTSMAN SPRINT CAR SERIES 94.0/14.0-15
 - SO CAL SPORTSMAN SPRINT CAR SERIES 96.0/14.0-15
 - Right Rear:
 - SO CAL SPORTSMAN SPRINT CAR SERIES 103-14.0-15

SO CAL SPORTSMAN SPRINT CAR SERIES will allow a "simple" re-groove and/or sipe ONLY on the factory pre-molded cross marks found on each individual block of the Hoosier tires. The groove is not to exceed the pre-molded marks. A #1 or #2 grooving head and blade is recommended. Be advised that these grooves may not extend into the sidewall of the tire.

There is to be NO siping (other than the pre-molded cross marks) or needling of the Hoosier tires. Light buffing is permitted, but MUST be done in a manner as to NOT create a sipe (cut/split) in the surface of the rubber. Note: Small cuts that are not consistent with a buffing pattern MAY be acceptable. Rule of thumb: If you can see it, it's too deep; if you can feel it, it is way too deep. (See the tech official for a ruling before competition).

Altering tires by any means of needling or chemical treating is strictly prohibited!

Burn-off: Newly-sanctioned speedways that previously had a crate engine Sprint Car programs will be permitted a burn-off period for previously allowed tires determined by Series Directors.

Speedway(s) and/or Series Officials have the ability to mandate the harder compound option on the right rear if track conditions warrant.

Series Officials may amend the tire rule for any event if track conditions warrant, and will inform competitors.

2. **WARNING:** SO CAL SPORTSMAN SPRINT CAR SERIES and Hoosier Racing Tires strictly forbids any chemical alteration of the tire carcass and/or tread compound such as tire soaking or use of tread "softener". SO CAL SPORTSMAN SPRINT CAR SERIES and Hoosier Tire strictly forbids the physical defacement (removal, altering, or covering) of tire sidewall markings in any manner. Failure to comply with this warning could result in premature or catastrophic tire failure and may result in serious injury or death.
3. Series may take physical samples of tire(s) to insure that no competitor has employed any chemicals to alter the performance of his or her tires at any time. Three samples will be taken per selected tire; samples will be taken by SO CAL SPORTSMAN SPRINT CAR SERIES or Track Official. Each sample from selected tire will be identified as sample #1, sample #2, and sample #3. Sample #1 will be retained by Series and sent to lab; sample #2 will be given to selected tire's driver/owner; and sample #3 will be retained by Series to be utilized as a tie-breaker in the event any issues may occur with samples #1 & #2. In the event driver/owner chooses to send sample #2 to be analyzed, SO CAL SPORTSMAN SPRINT CAR SERIES must approve selected lab. Tire samples not conforming to manufacturer's submitted factory benchmark will be deemed illegal.
4. It is the driver's responsibility to know what is on their race car at all times. Any used wheels or tires that may be suspect by the driver should not be used.
5. Any tire thought to be physically defaced or altered will be confiscated. While tire is in question, all money and points for that driver will be held until a ruling is made final. Any tire deemed to have been physically defaced or altered will be result in disqualification from the event (loss of money and points) along with the following:

PENALTIES FOR ILLEGAL TIRES:

- First Offense: \$500 fine & 30-day suspension from all future sanctioned events plus all related lab testing costs.
- Second Offense: \$1,000 fine & 90-day suspension from all future events plus all related lab testing costs.
- Third Offense: \$2,000 fine & 365-day suspension from all future plus all related lab testing costs.

Failure to allow any tire(s) to be confiscated for any reason by a SO CAL SPORTSMAN SPRINT CAR SERIES Official will result in a \$750 per tire fine and 45-day suspension from all future events in addition to any other fines and penalties. All decisions are final.

SHOCKS:

Shock absorbers are restricted to six part numbers manufactured by Bilstein on a proprietary basis for the SO CAL SPORTSMAN SPRINT CAR SERIES Sprint Car Series (sold at \$140).

The only allowable part numbers are:

- RUSH 1-5
- RUSH 7 4.5-5
- RUSH 8 4.5-4.5
- RUSH 8 5-3.5
- RUSH 8 8.5-3
- RUSH 8 7-3

Each shock is identified by the word **RUSH** then the stroke length of the shock. The following number after the stroke length number is the rebound damping value expressed by a whole number, a dash, and then the compression damping value expressed by a whole number. Example: RUSH7 1-5. This is a 7" stroke SO CAL SPORTSMAN SPRINT CAR SERIES/RUSH shock with a 1 rebound and a 5 compression, and would be referred to in the industry as an "easy up". Suggested SO CAL SPORTSMAN SPRINT CAR SERIES Sprint Car Bilstein Shock Setup Guide is available here: <https://www.rushsprintcars.com/Bilstein%20Shock%20Setup%20Guide%20Sprints.pdf>

Only SO CAL SPORTSMAN SPRINT CAR SERIES Sprint Car Series/RUSH shocks by Bilstein may be used in competition at any location on the race car. Only one shock absorber is allowed per wheel.

Shock covers permitted, but must be removed for all technical inspections.

Shocks may not be altered in any way; shock shafts may not be shortened nor strategically bent to seek a handling advantage, gas pressure must not have been altered, and no tampering with the pistons, seals, oil, shock body or valve stack is allowed. SO CAL SPORTSMAN SPRINT CAR SERIES competitors agree to willingly relinquish any one or all shock(s) from any position or all positions on his or her race car that comes into question to SO CAL SPORTSMAN SPRINT CAR SERIES tech officials for dyno testing and inspection to determine whether it is, or is not, a legal, unaltered shock. Shock(s) confiscated for further testing will be tagged by a numbered wire seal with Bilstein part numbers and wire seals documented on an official SO CAL SPORTSMAN SPRINT CAR SERIES Shock Confiscation form. Competitor must accept from tech officials a shock(s) of the same valving part number in return for the shock(s) relinquished.

If, upon dyno testing and inspection, it is determined that the gas pressure, seals, piston, oil, shock tube, rod, or valving has been altered in any way, the shock absorber will be determined illegal and SO CAL SPORTSMAN SPRINT CAR SERIES published penalties will apply.

SO CAL Sportsman Sprint Car Series Officials reserve the right to technically inspect exchange and/or confiscate any specified Bilstein sealed shock at any time. Failure to surrender the shock(s) and/or submit the shock(s) for inspection equals disqualification from the night's event, loss of all Series points to date, suspended from all PAS-sanctioned Series competition for 365 days, and fined \$1,000.

Any violation of the SO CAL SPORTSMAN SPRINT CAR SERIES Bilstein spec shock rule will result in the driver being disqualified for the night's event, loss of all Series points to date, suspended from all PAS-sanctioned Series competition for 365 days, and fined \$1,000.

WEIGHT:

1. 1550 lbs. with driver after the race.
2. Any car that is found light at the scales following qualifying/time trials will lose its time and start from the rear of a heat. Any car that is light at the scales following a heat race, B main/consy, or feature will be disqualified from the event. The track scales will be considered the official scales for the event.
3. Additional bolt-on weight will be permitted, but **MUST** be mounted and fastened to the frame and/or chassis in a secure manner. All additional bolt-on weight **MUST** be mounted and fastened in the area between the bottom frame rails, front and rear axles, and no higher than midrails at cockpit. All weight **MUST** be mounted within confines of frame. Bolt-on weight must be painted white with car number. No weight may be added during yellow or red flag. Penalty for losing weight on race track is disqualification from the event they are competing in.

BODY:

1. Only standard type Sprint Car bodies, tail tanks and hoods permitted.
2. An effective firewall must be installed between the engine compartment and the cockpit. It must be as leak proof as practical.
3. Carbon fiber material or its derivatives is not allowed for any body panels or other components.
4. Side foils, rudders and/or panels that extend beyond the rear of the cage support bars will not be permitted.
5. Nose pieces and/or the top portions of the hood must not extend forward of the leading edge of the front torsion tube. Torsion tubes must be positioned in what is considered a conventional location. The hood side paneling or other side body pieces must not extend forward of and/or below the front axle.
6. Sun visors must not extend forward more than 9" from the front of the forward most edge of the roll cage/halo tube, and may not be wider than the width of the roll cage. Sun visors must be flat on both sides. Sun visors may not obstruct driver's vision and will be at the discretion of Track Officials.
7. Wedges and/or foils underneath the racecar will not be permitted.
8. Pieces that are added to the basic frame to resemble imitate and/or be specifically designed to deflect, trap and/or form a pattern for air to travel in a directed manner, except for those used to cool and/or protect the motor and the brake system will not be permitted.
9. Mirrors of any kind, whether attached to the racecar and/or the driver will not be permitted.
10. All cars will be required to run a full sprint car type hood. Side panels covering the sides of the engine and/or vertical spill plates may not extend vertically more than 1" higher than any part of the hood covering the engine bay behind the front engine mount.
11. Right side cockpit panels must have a minimum opening of 100 square inches. Panels that restrict the driver's vision will not be permitted; and will be determined at the discretion of Track Officials. .
12. Safety bar(s) and/or arm guard paneling that protrude outward from the frame rails for the purpose of creating room for the driver will be permitted. The guard(s) and/or paneling will be permitted to extend a maximum of 7"-inches as measured from the outside edge of the middle frame rails and must remain above the middle frame rail. The sole purpose of this area is creating elbow room for the driver. The elbow room must remain above the upper "middle" frame rail and may not extend rearward of the leading edge of the rear axle. Reference 15.7 P for additional information concerning body panels.
13. A maximum 1 ½ inch wide by 20-inch long exhaust fume deflector, located on the bottom side-body panel at the rear edge will be permitted. The turnout angle must not exceed 90 degrees.
14. Other side paneling must be fabricated flat and must not extend past the outside edge of the frame rails more than the thickness of the paneling material.
15. Side body panel designs and/or concave surfaces that are intended to trap alter and/or direct airflow for the purpose of gaining an aerodynamic performance advantage will not be permitted; to be determined at the sole discretion of Track Officials.
16. Water radiators, oil coolers, battery and any remote engine accessory "must" be within the confines of the main frame tubes located between front axle and rear engine mounting plate.
17. Panels attached to nerf bars will not be permitted.

Gauges and Dash Modules:

1. Gauges to monitor engine conditions are permitted but will be limited to the following:
 - Oil pressure
 - Oil temperature
 - Engine coolant pressure
 - Engine coolant temperature
 - Fuel pressure
 - Battery voltage
 - Engine RPM
2. All electronic gauges whether analog or digital, except tachometers, will only be permitted to have one (1) input from the respective gauge sensor. Outputs from the gauges will not be permitted. Tachometers will be permitted to record engine RPM for recall and playback.
3. When an electronic dash module is used in lieu of individual gages, only the inputs as described above for individual gauges will be permitted. All other input channels must be disabled and blocked off from usage. Only engine RPM may be recorded. Wiring to the electronic dash module must be accessible and removable for ease of inspection.
4. All additional wiring harnesses related to electronic dash modules or any other type of data acquisition must be completely removed from the race vehicle during an event.

TRACTION CONTROL/RADIO/TRANSMISSION DEVICES:

1. All Traction Control Devices are strictly prohibited during any form or portion of a SO CAL SPORTSMAN SPRINT CAR SERIES event, race or practice/test session.
2. All traction control devices, whether electronically controlled in the ignition system, wheel sensors or any means of measuring ground speed to control wheel spin, are strictly prohibited. All devices not mentioned in the above that are found to control wheel spin, timing or fuel delivery control will be considered strictly prohibited.
3. At NO time will there be any type of ping control devices, remote devices that modify RPM and/or timing, automated throttle controls, timing controls, or any modifications to the ignition control boxes, distributors, or any other part of the Ignition System. This includes any add on component or components inside or outside the cockpit of any competitor's race car. There shall be NO driver controlled wheel spin, timing or fuel delivery control devices in the cockpit area of any race car. Remote control components utilized to affect and/or control wheel spin, timing or fuel will not be permitted.
4. Adjustable restrictor plates will not be permitted.
5. Radios and/or devices transmitting voice and/or data will not be permitted.
6. Data acquisition systems will not be permitted.
7. A competitor found with any of the devices mentioned under Traction Control/Radio/Transmission Devices, #1-6, will be disqualified from the event (loss of points and monies), forfeit the device permanently and the following:
 - First Offense: \$500 fine & 30-day suspension from any future event plus any testing costs, if required
 - Second Offense: \$1,000 fine & 90-day suspension from any future event plus any testing costs, if required
 - Third Offense: \$2,000 fine & 365-day suspension from any future event plus any testing costs, if required
8. A competitor refusing to relinquish any of the above mentioned will result in disqualification from the event (loss of points and monies) and "refusal of tech" penalties.
9. GPS and/or any other type of electronic tracking and/or locating/positioning device will not be permitted for any reason. If found, driver and car will be disqualified for the night (loss of points and monies), and will forfeit device permanently.
10. GoPro and/or similar camera devices are permitted providing they do not interface with the car, electronic or otherwise, and do not transmit any signals. Cameras not meeting specifications, will result in driver and car being disqualified for the night (loss of points and monies), and will forfeit device permanently.
11. Antennas will not be permitted in and/or attached to the race vehicle or carried by the driver. If found, driver and car will be disqualified for the night (loss of points and monies), and will forfeit antenna permanently.

DRIVER RADIOS:

All drivers are required to have a one-way radio set to the race/scoring frequency (464.5500) to be utilized for communication from Track and/or Series Officials. The one-way radio must be working and active prior to any 'on-track' activity. Two-way radios, crew-member to driver and/or any other means of electronic communication, other than the one-way radio, will not be permitted.

TRANSPONDERS:

1. If used, only approved transponders (lap timing and/or lap time recording devices) permitted (see each track's rules for more info).
2. When required, transponders shall be located on the right side behind the front torsion bar tubes on the vertical bracket (see Drawing 16.11.1. E below) unless another area is determined by SO CAL SPORTSMAN SPRINT CAR SERIES or Track Officials. The fitted transponder box shall be mounted as close as possible to the ground, but not protrude below the frame rail. It is the responsibility of the competitor to ensure that the transponder is in quality working condition, fully charged and is securely mounted and is in a suitable position with brackets as outlined above. It is in everyone's interest that transponders are suitably and securely attached and are in good working condition.

SAFETY / PERSONAL SAFETY EQUIPMENT:

General

1. Each competitor is the solely responsible of for the effectiveness and proper installation, per the manufacturer's specifications, of personal safety equipment and determining it to be adequate for competition at every event.
2. Each competitor is expected to investigate and educate themselves for continuing improvement regarding their own personal safety equipment.

Halos

1. Sprint Car roll cage halos are mandatory. Halo minimum 1 1/2" x .095"

Protective Clothing

1. All drivers will be required to wear a fire resistant driving uniform meeting minimum of the SFI 3.2A/5 specification and display a valid SFI 3.2A/5 label on the outside of the uniform. Uniform must be worn at all times driver is on the track including engine starts, practice, and competition.
2. Drivers must wear gloves at all times they are on track including engine starts, practice, and competition.
3. Driver's gloves must meet or exceed the SFI 3.3 specification and have a legible and valid SFI 3.3 label.
4. All drivers should wear fire resistant accessories including but not limited to; head sock, under garments, shoes, and socks. All drivers will be required to wear fire resistant gloves. Shoes and gloves will be required to meet minimum of the SFI 3.3 specifications and display a valid SFI 3.3 label.

Full Containment Seats

1. Seats must be full containment type constructed of aluminum or approved carbon fiber. Carbon fiber seats must have a current valid SFI 39.2 Certification.
2. All seats must be mounted to the frame as required by the seat and chassis manufacturer, and installed and used in accordance with the manufacturer's instructions.
3. **The following full containment seats have been approved for competition:**
 - A. Butlerbuilt – Advantage, EZ Series, BBP-1308-02 ProSprint
 - B. The Joie of Seating – SPR01, Full Custom, DL-SS-2014 Sprint Custom
 - C. Richardson – R39, R39 Deluxe iv. Fiberworks – SCS
 - D. Kirkey – 69 Series, 79 Series, 89 Series
 - E. Ultrashield – VS Halo – 72000, 720000, 75000 and 8000 Series g

The approved driver's seats may be revised from time-to-time with additional approvals and/or other changes to the approved list.
3. The driver's left side head rest / helmet surround must extend at least 4"-inches forward from the back of the headrest (where the helmet contacts the back of the headrest). All areas surrounding the head should have padding.
4. An approved driver's cockpit net is mandatory for the left side if the Helmet head rest / helmet surround is less than 7"-inches forward from the back of the seat. The net must be a minimum of three (3) ribbons and should meet the SFI 37.1 specifications, installed per the Manufacturer's specifications.
5. The following nets have been approved for competition:
 - A. Safety Solutions (Sprint Car Net)
 - B. Simpson DN-SPR
 - C. Speedway 91073

The approved nets may be revised from time-to-time with additional approvals and/or other changes to the approved list.
6. A right side head restraint net and/or support are required. All head restraint nets should be equipped with quick release mechanisms.

Seat Belt/Restraint System

1. Each car will be equipped with minimum of an SFI 16.5 or SFI 16.1 approved restraint system, until the date of the belt expiration (two years from the date of manufacturer). Seat belt restraint systems shall be installed and used in accordance with manufacturer's Instructions. In any type of manufacturer's installation the fasteners must be supplied by the manufacturer unless using type of mount in which the seat belt wraps around the roll cage. A seven-point harness is recommended.
2. Seat belt material should not be permitted to come in contact with any sharp or metal edge, including when the material passes through the seat.

Arm Restraints

1. Arm restraints with a 3.3 SFI certification are mandatory and must be worn at all times during competition; must be connected and used as instructed by the manufacturer.

Helmets

1. All drivers must wear a full-face helmet with a minimum safety rating of FIA 8860-2010, Snell SA 2015, Snell SA 2010, Snell SAH 2010, and/or a valid SFI 31.1/2005 label.
2. It is strongly recommended that helmets should have the Eject™ helmet removal system installed as per the manufacturer's instructions.

Head and Neck Restraints

1. At all times during an event including practice, qualifying and competition (excluding starting the car for engine warm-up) drivers MUST wear an SFI-approved head and neck restraint device/system that is properly mounted and connected per the manufacturer's instructions. The device should meet SFI 38.1 specifications and display a valid SFI 38.1 label.
2. The head and neck restraint must be SFI 38.1 approved and display a legible and valid SFI 38.1 label.

Rock Screen/Windshield

1. A magnetic steel rock screen (windshield) with a minimum thickness of 0.090" is mandatory and must be securely fastened to the roll cage, i.e. with split and/or hose clamps.

Onboard Fire Suppression System is highly recommended. (King Racing Products Part #KRP-5030 is a SO CAL SPORTSMAN SPRINT CAR SERIES approved Sprint Car System)

Personal Safety - Other RECOMMENDED

1. No sharp and/or protruding edges in and around the cockpit.
2. Only SFI flame retardant seat, roll bar, knee and steering pads and/or padding should be utilized.
3. All teams should have an easily accessible 2.5 gallon FFF fire extinguisher or its equivalent at the back of the team's transporter.

GENERAL CAR INSPECTION:

All cars may be subject to technical inspection at any time. Any driver that fails to cooperate and/or allow an inspection of his car at any time will be subject to disqualification, a 45-day suspension, and \$750 fine.

FINES, PENALTIES, SUSPENSIONS & APPEALS

PRE-RACE TECHNICAL VIOLATION:

If a technical violation(s) is found during pre-race technical inspection, the driver/team will be advised of the violation and must meet full compliance before being allowed to compete.

REFUSAL OF TECH

A refusal of tech and/or failure to allow an official to confiscate a part(s), other than the already previously stated individual refusal penalties/suspensions, will result in a 45-day suspension and \$750 fine. All illegal parts will be confiscated.

FINES & PENALTIES:

If an entrant is disqualified for any reason, any fine and /or suspension apply to both the driver and car owner if not the same person. In other words, if an entrant is disqualified for a technical violation, such as an engine not in compliance with tech specs, neither the owner nor the driver can race for the suspension period, and while only one fine will be charged, neither party can race until that fine is paid. Fine must be paid in full to Series by cash or certified check in order to compete once suspension period ends. NOTE: If suspension includes 'a number of days' clause and occurs at the end of the season when no additional events exist, suspension will carry over to the following year beginning with the first actual event.

EVENT SUSPENSIONS:

Driver/Owner suspended for any infraction will carry over to any other divisions and will preclude driver/owner from competing at **ANY** event until suspension is lifted.

MULTIPLE INFRACTIONS:

In the event driver and/or car is disqualified in post-race tech for the same technical rules infraction twice (excluding engines within the sealing system, tires, fuel, and shocks, springs, suspensions rules- see each rule for specific penalties), driver and car will be suspended for 7 days from all events. Each successive infraction will carry an additional 7-day suspension. In the event an entrant fails technical inspection for multiple infractions that each carry a suspension and/or fine at the same event, suspension and/or fine will compound and accumulate with each infraction.

LEGALITY OF PARTS:

If SO CAL SPORTSMAN SPRINT CAR SERIES DIRECTOR or Track Tech Official is unsure of the legality of a part, said part will be sent to GM or to SO CAL SPORTSMAN SPRINT CAR SERIES Office for inspection. At this time, finishing position will be frozen until legality of the said part is determined. In the event of a disqualification, finishing position, points and monies would be adjusted accordingly. **ALL ILLEGAL PARTS WILL BE CONFISCATED & DESTROYED!** Not allowing confiscating of parts is considered "cheating within the bolts" and said penalties will be imposed.

FINALITY OF DECISIONS AND INTERPRETATIONS AND COVENANT NOT TO SUE:

The decisions of Track Officials or promoter at an event, including the interpretation and application of rules and the scoring of positions, shall be FINAL, BINDING, and NON-APPEALABLE, except in the case of a suspension or fine, which is further explained in the SUSPENSIONS/FINES & APPEALS category.

All participants, as a condition of participating in an event, agree that ALL decisions of officials or the promoter, regarding the interpretation and application of the rules, and the scoring of positions, shall be NON-LITIGABLE. All participants further covenant and agree that they will NOT initiate any of legal action against Oval Entertainment, LLC dba Perris Auto Speedway or Ventura Raceway, the promoter, and officials to challenge such decision, to seek monetary damages, to seek injunctive relief, or to seek any kind of legal remedy. If a participant pursues any such legal action, which violates this provision, then the participant and/or owner expressly agrees to reimburse Oval Entertainment, LLC dba Perris Auto

Speedway or Ventura Raceway, for ALL of its ATTORNEY FEES and COSTS IN DEFENDING AGAINST SUCH LEGAL ACTION. By signing the annual registration agreement, participants agree that they will comply with the written rules and procedures of the Series. In the event that he or she would breach the registration agreement, he or she shall be liable for actual and liquidated damages sustained by Oval Entertainment, LLC dba Perris Auto Speedway or Ventura Raceway.

APPEALS PROCESS:

SO CAL SPORTSMAN SPRINT CAR SERIES DIRECTORS will determine any and all suspensions/fines that are covered in the rules and any violation that may come up during the year. SO CAL SPORTSMAN SPRINT CAR SERIES DIRECTORS will make judgment on the sanctions, and violator(s) will be sent official notice by a certified letter, return receipt requested.

Driver and/or car owner has the opportunity to appeal his or her sanction and must do so in writing accompanied by any relevant documentation. Appeal must be in writing and e-mailed to kazariandon@gmail.com 48 hours of notification of violation.

SO CAL SPORTSMAN SPRINT CAR SERIES will then set a date and time for a zoom online appeal hearing. The violator(s) will present his/her case to the SO CAL SPORTSMAN SPRINT CAR SERIES DIRECTORS. The violator(s) and one other person are permitted to attend the appeal hearing. Additional attendees must be approved by SO CAL SPORTSMAN SPRINT CAR SERIES DIRECTORS pursuant to a written request.

Following the appeal hearing with the violator(s), SO CAL SPORTSMAN SPRINT CAR SERIES DIRECTORS may conduct further follow-ups, meetings, etc. with any other necessary party(s). Judgment will then be rendered to the violator by a certified letter, return receipt.

Violator(s) agrees that the decision made will be final and party posting appeal has no legal rights thereafter. In the event of a protest, the party that protested also agrees to accept final ruling on decision and has no legal rights thereafter.

MISREPRESENTATION

False or inaccurate statements or information provided to SO CAL SPORTSMAN SPRINT CAR SERIES DIRECTORS in any instance(s) will render it void, and will excuse SO CAL SPORTSMAN SPRINT CAR SERIES DIRECTORS from any obligation created herein. Further, SO CAL SPORTSMAN SPRINT CAR SERIES DIRECTORS reserves the right to seek compensation for any damage suffered as a result of its reasonable reliance on the information provided.

DRAWINGS:

#1 Support Bar

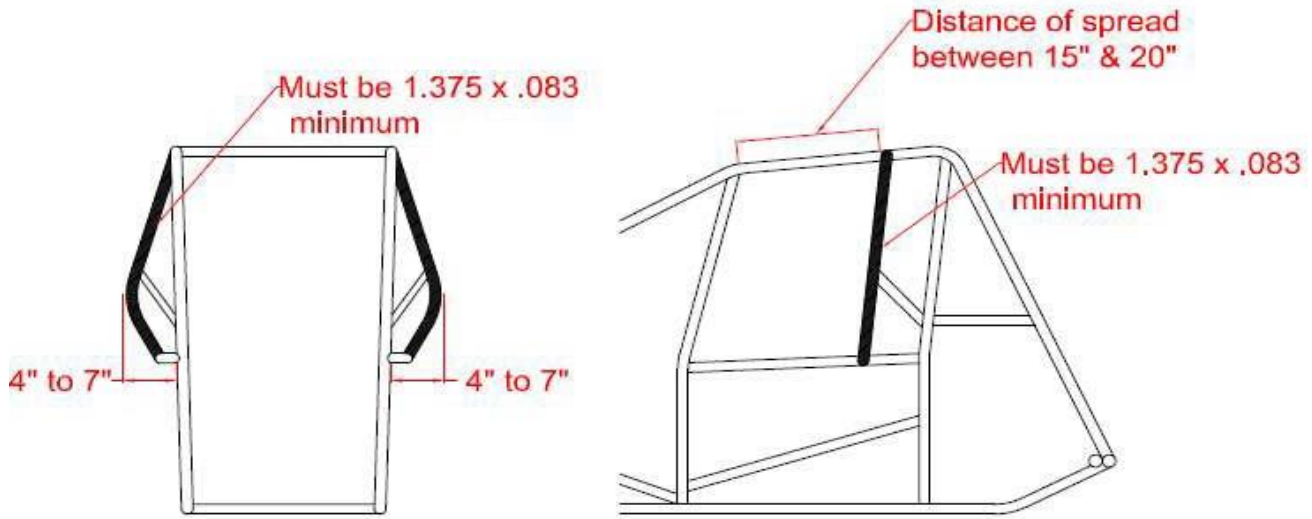

Diagram 16.12.1
By Tom Devitt

#2 Support Bar

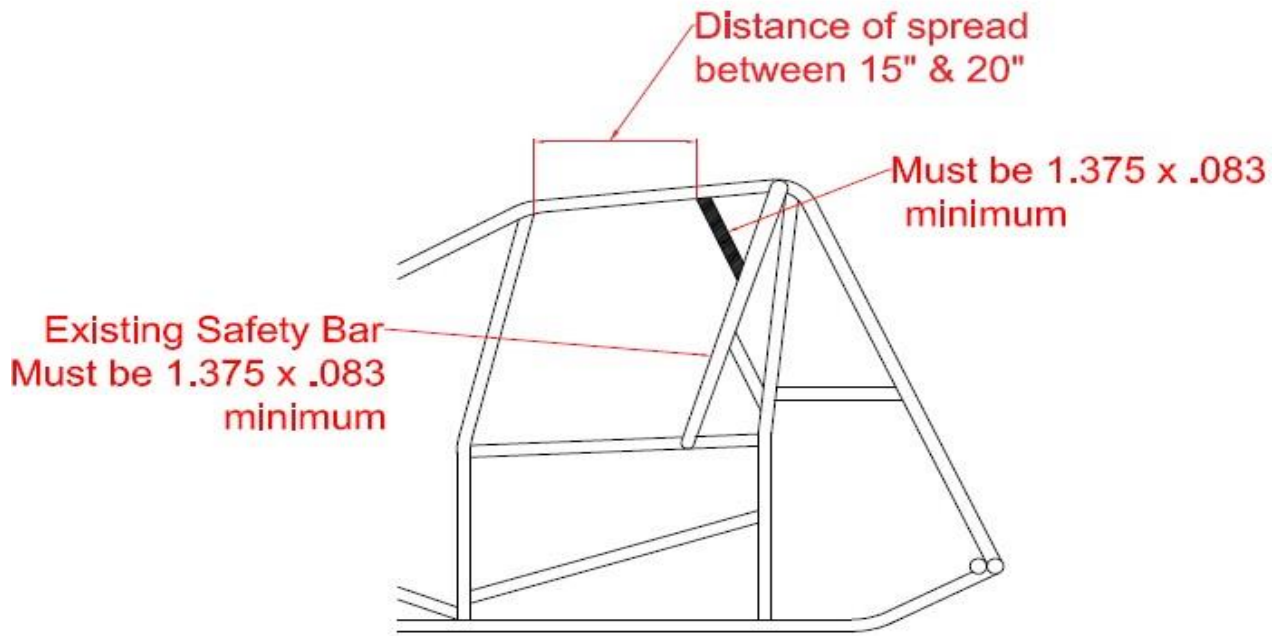
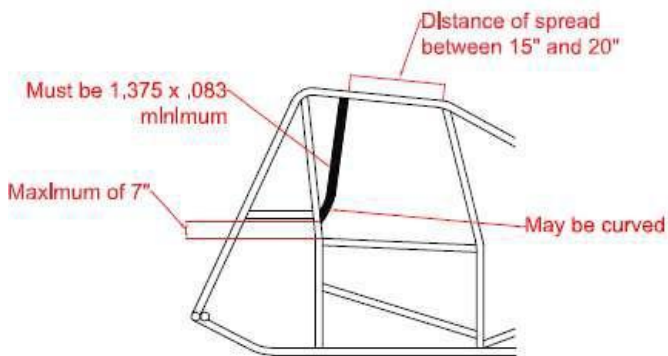
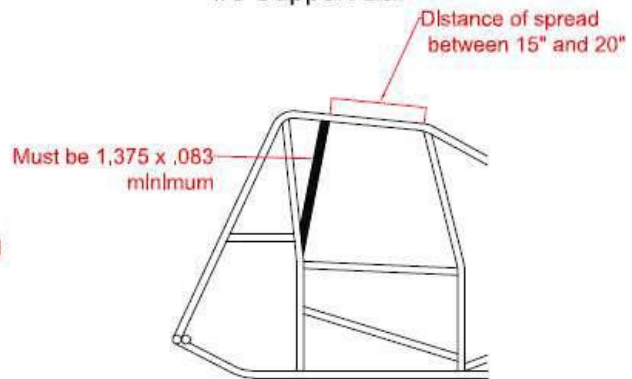

Diagram 16.12.2
by Tom Devitt

#3 Support Bar Curved Option



#3 Support Bar



Drawing 16.12.3
By Tom Devitt

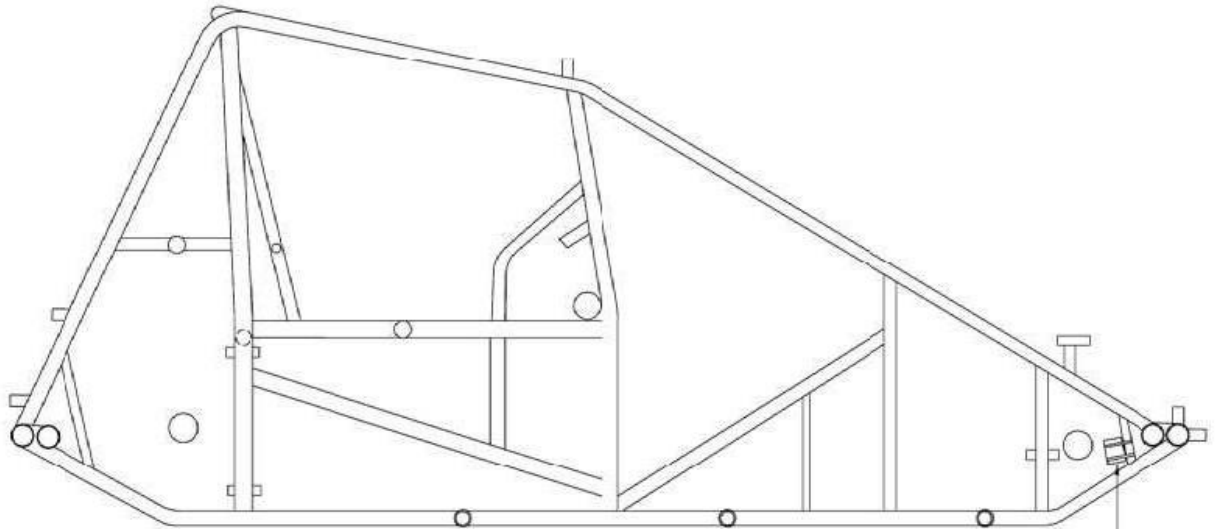

AMB TRANSPONDER
(SEE PHOTO)

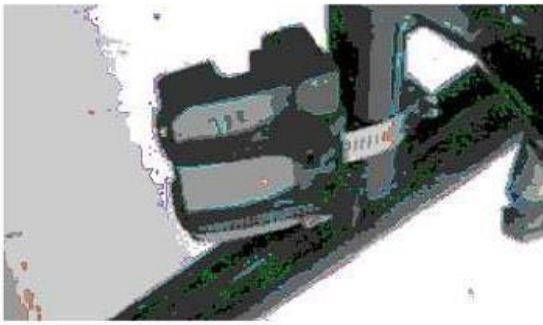

SPRINT CAR TRANSPONDER LOCATION	
	DWG #: 16.11.1.E
DRAWN BY:	BARRETT WAGONER
CHECKED BY:	CARLTON REIMERS
UPDATED BY:	BARRETT WAGONER

RACE FORMAT, PURSE AND CHAMPIONSHIP POINTS STRUCTURE

All cars will Pill Draw for starting positions in your Heat Race.

All Heat Races will be 8 laps.

A 10 Lap B Main will run if the car count is above 20 Cars. In this case, the top four Cars from the Heat Races will transfer to the A Main, The remaining Cars will be lined up for the B Main based on their finishing order in the Heats.

Main Event will be 20 Laps. The inversion for the Main Event will be decided by the winner of the first heat race by pulling a pill from 1 to 10. The inversion will be from straight up to a full field inversion.

The (2) Two spin rule will be in effect for all races,

The minimum car count to qualify for a Purse is 10 Cars. The Purse for 10 cars and above is as follows;

2021 So Cal Sprint Car Purse

Pay Out / Number of Cars

POS	A MAIN POINTS	16+	11-15	10
1	20	\$1,000	\$700	\$350
2	19	\$700	\$500	\$250
3	18	\$500	\$400	\$200
4	17	\$350	\$300	\$175
5	16	\$250	\$200	\$150
6	15	\$225	\$175	\$125
7	14	\$200	\$150	\$100
8	13	\$175	\$125	\$90
9	12	\$165	\$115	\$80
10	11	\$160	\$110	\$75
11	10	\$155	\$105	
12	9	\$150	\$100	
13	8	\$140	\$90	
14	7	\$130	\$80	
15	6	\$125	\$75	
16	5	\$120		
17	4	\$115		
18	3	\$110		
19	2	\$105		
20	1	\$100		
		\$4,975	\$3,225	\$1,595